

H1600RR

H820 Straight running chain

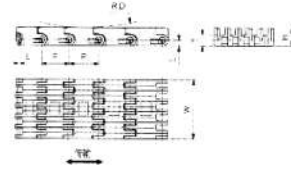

Chain Code 产品编号	Width 链宽		Thickness 厚度		Working Load(max) 工作载荷		Temperature 温度		Pitch 节距		Material 材质
	mm	inch	mm	inch	N	lbs	dry	wet	mm	inch	
H1600RR-K30	30	1.18	8.7	0.34	315	73	+4 to +80°C	+4 to 65°C	25.40	1.00	POM
H1600RR-K38.5	38.5	1.52	8.7	0.34	415	96	+4 to +80°C	+4 to 65°C	25.40	1.00	POM
H1600RR-K47	47	1.58	8.7	0.34	500	115	+4 to +80°C	+4 to 65°C	25.40	1.01	POM

H2120

Flat top

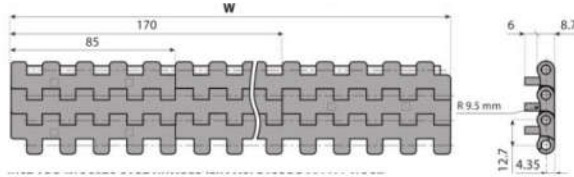

Chain Code 产品编号	Material 材质	Thickness 厚度		Pitch 节距		Working Load(max) 工作载荷		Temperature 温度		Backflex Radius(min) 反向弯曲半径
		mm	inch	mm	inch	N/m(21°C)	lb/ft(21°C)	dry	wet	
H2120	POM	14.70	0.58	12.70	0.50	21600	1480	+4 to +80°C	+4 to 65°C	50

H2250

Mold to width flat top

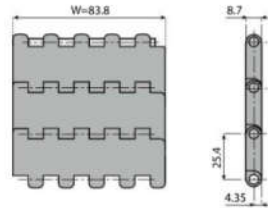

Chain Code 产品编号	Material 材质	Width 宽度		Pitch 节距		Working Load(max) 工作载荷		Temperature 温度		Backflex Radius(min) 反向弯曲半径
		mm	inch	mm	inch	N/m(21°C)	lb/ft(21°C)	dry	wet	
H2250	POM	83.80	3.30	25.40	1.00	21600	1480	+4 to +80°C	+4 to 65°C	50

H5997

Raised rib

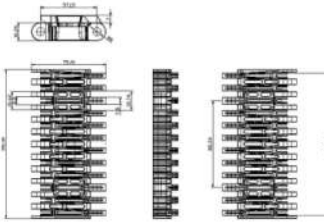

Chain Code 产品编号	Material 材质	Width 宽度		Pitch 节距		Surface Opening	Temperature 温度		Backflex Radius(min) 反向弯曲半径
		mm	inch	mm	inch		dry	wet	
H5997	POM	25.26	1.00	57.15	2.25	21%	+4 to +80°C	+4 to 65°C	50

SNB-M2

Open flush grid

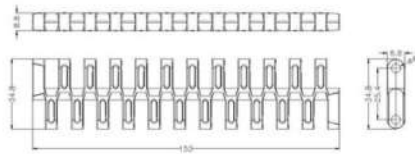
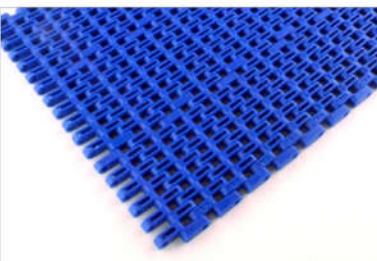

Chain Code 产品编号	Material 材质	Width 宽度		Pitch 节距		Surface opening 开孔率	Temperature 温度		Backflex Radius(min) 反向弯曲半径	Backflex Radius(min) 反向弯曲半径
		mm	inch	mm	inch		dry	wet		
SNB-M2	POM	8.8	0.38	25.4	1.00	34%	+4 to +80°C	+4 to 65°C	30	30



Plastic Chain

H900

Flat top



Pitch: 27.2mm

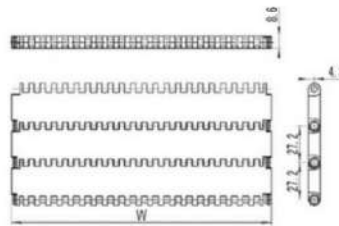

Belt Type 网链编号	Material 材质	Working Load(max) 工作载荷		Weight 重量	Temperature 温度		Backflex Radius (min) 反向弯曲半径
		N/m(21°C)	lb/ft (21°C)		dry	wet	
FT900	POM	21600	1480	7.30	+4 to +80°C	+4 to 65°C	50

H900

Perforated flat top



Pitch: 27.2mm

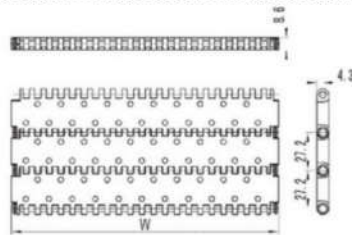

Belt Type 产品编号	Material 材质	Working Load(max) 工作载荷		Weight 重量	Temperature 温度		Backflex Radius (min) 反向弯曲半径
		N/m(21°C)	lb/ft (21°C)		dry	wet	
RFT900	POM	21600	1480	7.11	+4 to +80°C	+4 to 65°C	50

H900

Flush grid

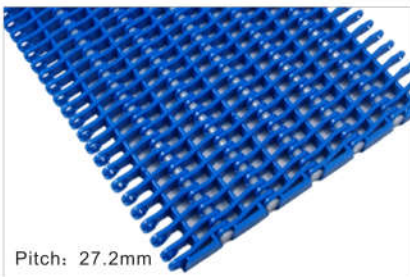

Pitch: 27.2mm

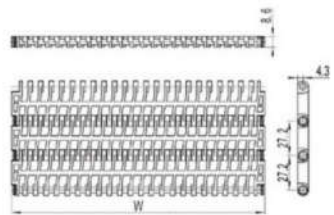

Belt Type 网链编号	Material 材质	Working Load(max) 工作载荷		Weight 重量	Temperature 温度		Backflex Radius (min) 反向弯曲半径
		N/m(21°C)	lb/ft (21°C)		dry	wet	
FG900	POM	21600	1400	5.62	+4 to +80°C	+4 to 65°C	50

H900

Raised rib

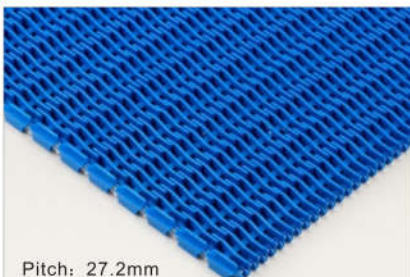

Pitch: 27.2mm

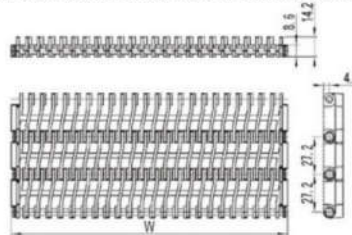

Belt Type 产品编号	Material 材质	Working Load(max) 工作载荷		Weight 重量	Temperature 温度		Backflex Radius (min) 反向弯曲半径
		N/m(21°C)	lb/ft (21°C)		dry	wet	
RR900	POM	21600	1480	8.19	+4 to +80°C	+4 to 65°C	25

H900TA-K138 H900TA-K165 H900TA-K181

Raised rib



Pitch:27.2mm Thickness:14mm Width:30,35,37,46

Belt Type 网链编号	Material 材质	Width 链宽	Working Load(max) 工作载荷		Weight 重量	Temperature 温度		Backflex Radius (min) 反向弯曲半径
		mm	N/m(21°C)	lb/ft (21°C)		dry	wet	
Narrow RR900	POM	30/35/37/46	21600	1480	8.19	+4 to +80°C	+4 to 65°C	50
	PP	30/35/37/46	10200	700	5.21	+5 to +104°C	+5 to +104°C	
	PE	30/35/37/46	5100	350	5.57	-46 to +66°C	-46 to +66°C	

H1000

Flat top

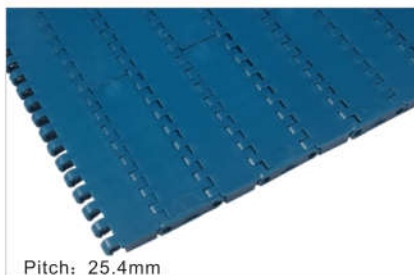

Pitch: 25.4mm

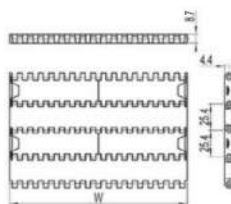

Belt Type	Material	Working Load(max)		Weight	Temperature		Backflex Radius(min)
		N/m(21°C)	lb/ft (21°C)		dry	wet	
FT1000	POM	22000	1507	6.50	+4 to +80°C	+4 to 65°C	25

H1000

Flat top

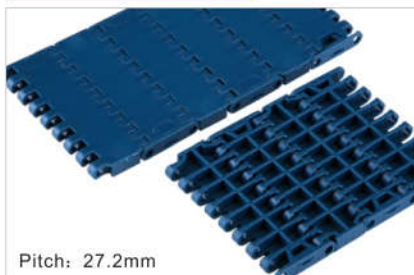

Pitch: 27.2mm

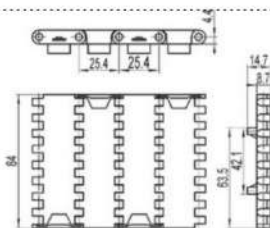

Belt Type 网链编号	Material 材质	Width 链宽 mm	Working Load(max) 工作载荷		Weight 重量 Kg/m'	Temperature 温度		Backflex Radius(min) 反向弯曲半径 mm
			N/m(21°C)	lb/ft (21°C)		dry	wet	
Narrow FT1000	POM	85	22000	1507	6.50	+4 to +80°C	+4 to 65°C	25

H1100

Flush grid friction top

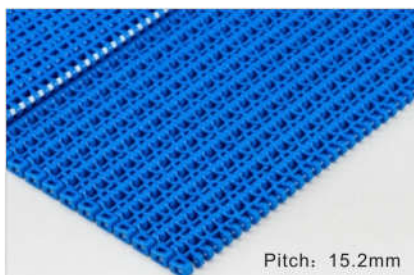

Pitch: 15.2mm

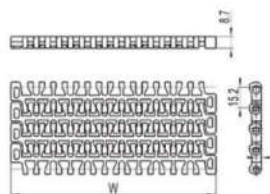

Belt Type 网链编号	Material 材质	Working Load(max) 工作载荷		Weight 重量 Kg/m'	Temperature 温度		Backflex Radius(min) 反向弯曲半径 mm
		N/m(21°C)	lb/ft (21°C)		dry	wet	
FG1100	POM	18980	1300	5.80	+4 to +80°C	+4 to 65°C	25

H1100

Flush grid friction top

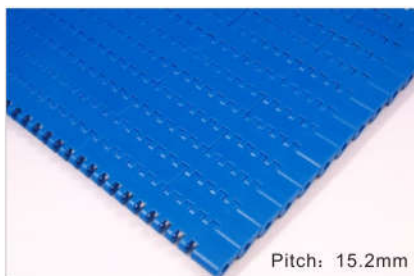

Pitch: 15.2mm

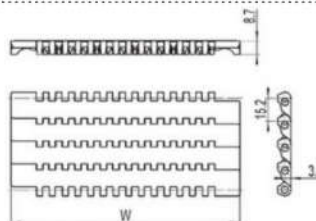

Belt Type 产品名称	Material 材质	Working Load(max) 工作载荷		Weight 重量 Kg/m'	Temperature 温度		Backflex Radius(min) 反向弯曲半径 mm
		N/m(21°C)	lb/ft (21°C)		dry	wet	
FT1100	POM	14600	1000	6.35	+4 to +80°C	+4 to 65°C	25
	PP	7300	500	4.40	+5 to +104°C	+5 to +104°C	

H3110

Raised rib



Pitch: 50.8mm

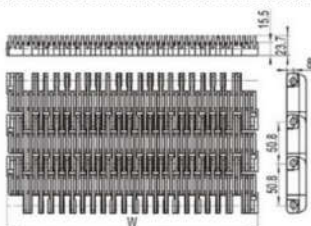

Belt Type 产品名称	Material 材质	Working Load(max) 工作载荷		Weight 重量 Kg/m'	Temperature 温度		Backflex Radius(min) 反向弯曲半径 mm
		N/m(21°C)	lb/ft (21°C)		dry	wet	
RR3110	PP	27380	1880	11.32	+5 to +104°C	+5 to 104°C	75



Plastic Chain

H5935

Flat top

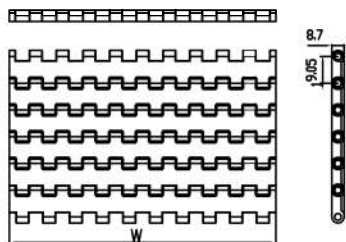
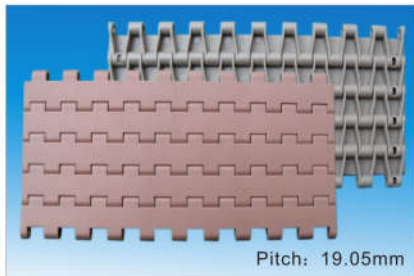

Belt Type 产品名称	Material 材质	Working Load(max) 工作载荷		Weight 重量 Kg/m ²	Temperature 温度		Backflex Radius(min) 反向弯曲半径 mm
		N/m(21°C)	lb/ft (21°C)		dry	wet	
FT5935	POM	7000	483	4.92	+5 to +105°C	+5 to 105°C	25

H5935

Mesh chain base flights

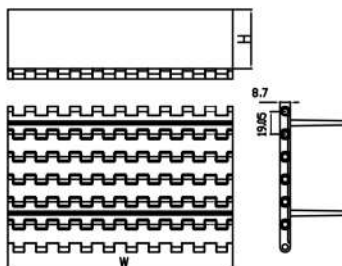
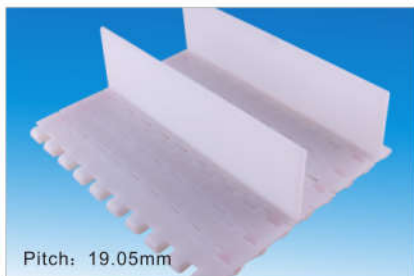

开孔率	组装方式	挡板高度(H)
0%	以边结芯轴连接	10MM-50MM

H5936

Mesh top

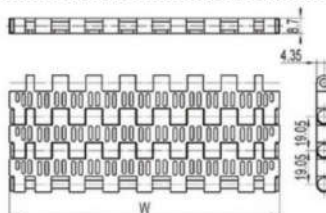

Belt Type 产品名称	Material 材质	Working Load(max) 工作载荷		Weight 重量 Kg/m ²	Temperature 温度		Backflex Radius(min) 反向弯曲半径 mm
		N/m(21°C)	lb/ft (21°C)		dry	wet	
FT5936	POM	7000	483	4.92	+5 to +105°C	+5 to 105°C	25

H5936

Mesh chain with baffle

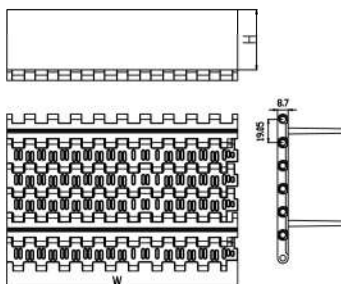
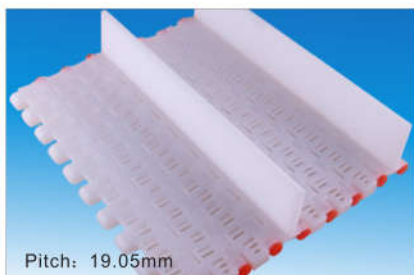

开孔率	组装方式	挡板高度(H)
35%	以边结芯轴连接	10MM-50MM

H7705

Flush grid

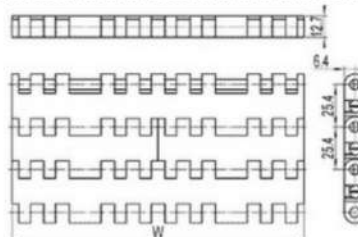
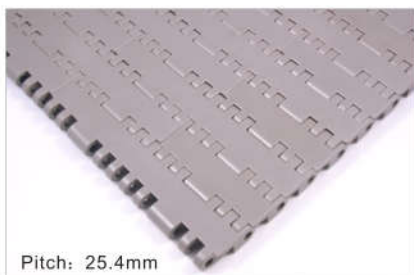

Belt Type 产品名称	Material 材质	Working Load(max) 工作载荷		Weight 重量 Kg/m ²	Temperature 温度		Backflex Radius(min) 反向弯曲半径 mm
		N/m(21°C)	lb/ft (21°C)		dry	wet	
FT7705	POM	43000	2945	13.47	-40 to +80°C	-40 to 65°C	25

H9705B

Flat top

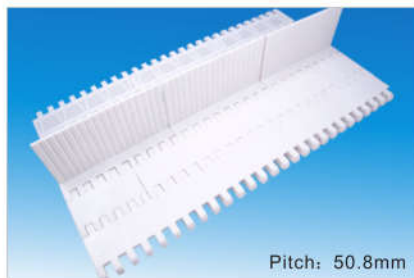

Pitch: 50.8mm

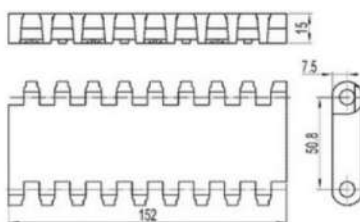

Belt Type 产品名称	Material 材质	Working Load(max) 工作载荷		Weight 重量	Temperature 温度		Backflex Radius (min) 反向弯曲半径
		N/m(21°C)	lb/ft (21°C)		dry	wet	
FT9705B	POM	22000	1507	11.7	+4 to +85°C	+5 to 65°C	25
	PP	11000	754	7.5	+5 to +104°C	+5 to 105°C	

H1600-85

Flush grid

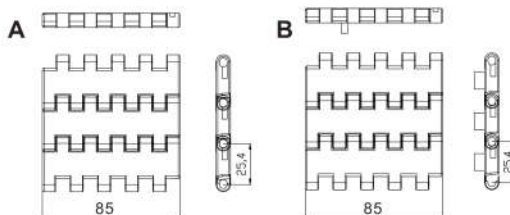

Belt Type 产品名称	Material 材质	Working Load(max) 工作载荷		Weight 重量	Temperature 温度		Backflex Radius (min) 反向弯曲半径
		N/m(21°C)	lb/ft (21°C)		dry	wet	
H1600-85	POM	35000	2398	8.4	+4to +80°C	+4to +60°C	40

H1600

Mold to Width Open Hinge Flat Top

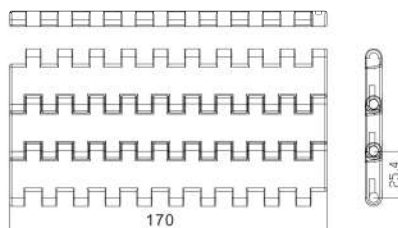

Belt Type 产品名称	Material 材质	Working Load(max) 工作载荷		Weight 重量	Temperature 温度		Backflex Radius (min) 反向弯曲半径
		N/m(21°C)	lb/ft (21°C)		dry	wet	
H1600	POM	35000	2398	8.4	+4to +80°C	+4to +60°C	40

H2400Z

Flush grid



Pitch: 25.4mm

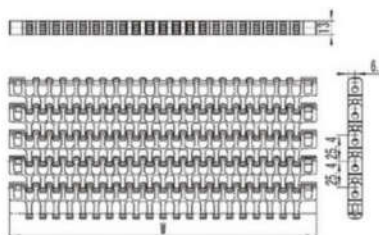

Belt Type 产品编号	Belt Material 材质	Working Load(max) 工作载荷		Weight 重量	Temperature 温度		Backflex Radius(min) 反向转弯半径	
		N/M(Straight)	N(Curved)		Kg/m	Dry	Wet	mm
H2400Z	POM	24800	1100	10.8	-40 to+80°C	-40 to+65°C	50	1.97

H2200

Radius flush grid

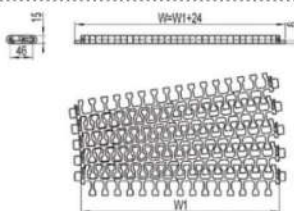
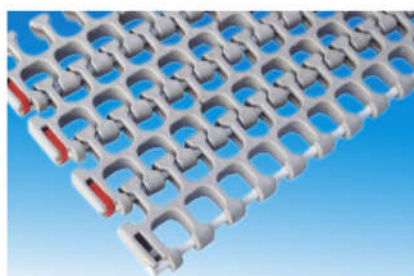

Belt Type 产品名称	Material 材质	Working Load(max) 工作载荷		Weight 重量	Temperature 温度		Backflex Radius (min) 反向弯曲半径
		N/m(21°C)	lb/ft (21°C)		Kg/m'	dry	
H2200	POM	27000	1300	9.7	+4to +80°C	+4to +60°C	50
H2200	PA			8.4	-46to +116°C	-46to +116°C	50



Plastic Chain

H850

Vacuum chain

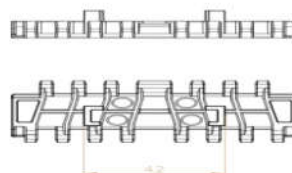
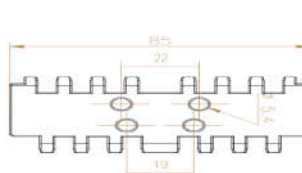

Chain Code 产品编号	Material 材质	Thickness 厚度		Pitch 节距		Belt width 链宽		Temperature 温度	
		mm	inch	mm	inch	mm	inch	dry	wet
H850	POM	9.8	0.385	27	1.06	85	3.35	+4 to +80°C	+4 to 65°C

H700A-69

Mold to width flat top

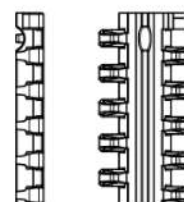
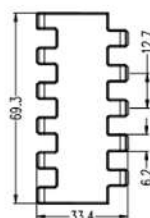

Chain Code 产品编号	Material 材质	Thickness 厚度		Pitch 节距		Belt width 链宽		Temperature 温度	
		mm	inch	mm	inch	mm	inch	dry	wet
H700A-69	POM	6.3	0.248	25.4	1.00	69.3	2.728	+4 to +80°C	+4 to 65°C

H700A-101

Mold to width flat top

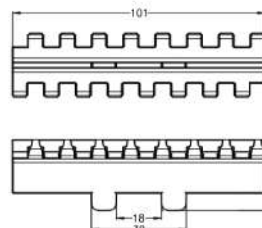
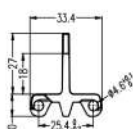

Chain Code 产品编号	Material 材质	Thickness 厚度		Pitch 节距		Belt width 链宽		Temperature 温度	
		mm	inch	mm	inch	mm	inch	dry	wet
H700A-101	POM	6.3	0.248	25.4	1.00	101	3.976	+4 to +80°C	+4 to 65°C

H610

Radius flush grid

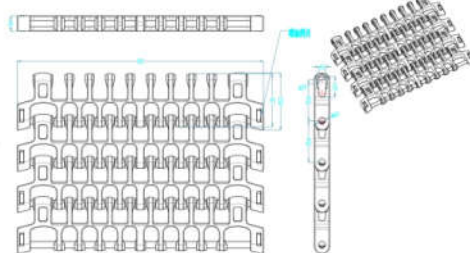

Chain Code 产品编号	Material 材质	Thickness 厚度		Pitch 节距		Width 宽度	Temperature 温度	
		mm	inch	mm	inch		dry	wet
H610	POM	9.4	0.37	25.4	1.00	152	+4 to +80°C	+4 to 65°C

H2200V

Flexible mesh chain

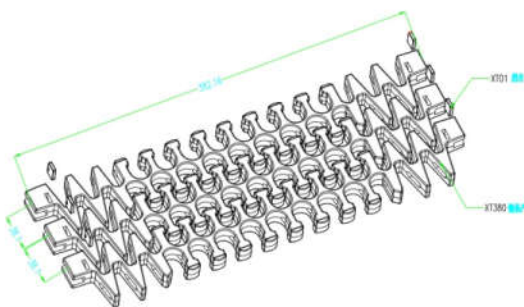

Chain Code 产品编号	Material 材质	Width 宽度		Pitch 节距		Temperature 温度	
		mm	inch	mm	inch	dry	wet
H2200V	POM	382.16	15.05	38.1	1.5	+4 to +80°C	+4 to 65°C

H1500

Mold to width flat top

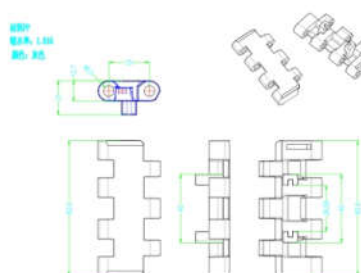

Chain Code 产品编号	Material 材质	Width 宽度		Pitch 节距		Temperature 温度		Color 颜色
		mm	inch	mm	inch	dry	wet	
H1500	POM	82.6	3.25	25	0.98	+4 to +80°C	+4 to 65°C	Grey

H1300

Flat top

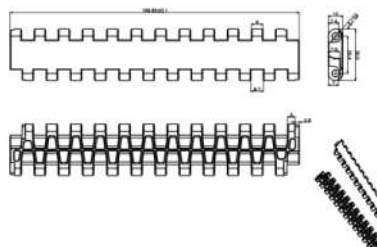

Chain Code 产品编号	Material 材质	Working Load max		Pitch 节距		Temperature 温度		Thickness 厚度
		N/(m ²)	lb/ft ²	mm	inch	dry	wet	
H1300	POM	22000	1507	25.4	1	+4 to +80°C	+4 to 65°C	10

H2120

Mold to width flat top

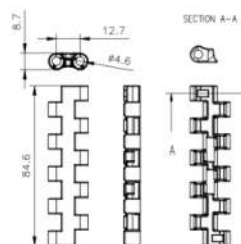

Chain Code 产品编号	Material 材质	Width 宽度		Pitch 节距		Temperature 温度		Color 颜色
		mm	inch	mm	inch	dry	wet	
H2120	POM	84.6	3.33	12.7	0.5	+4 to +80°C	+4 to 65°C	Grey



Plastic Chain

OPB mesh chain

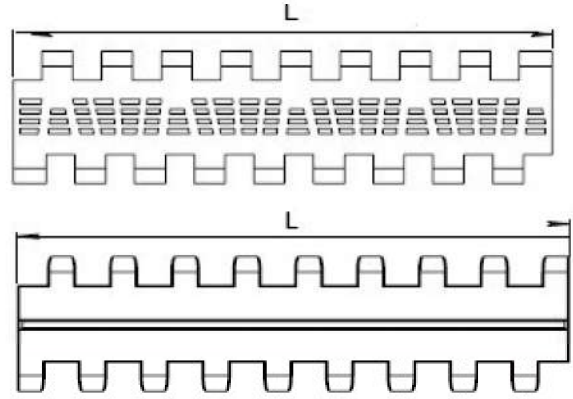
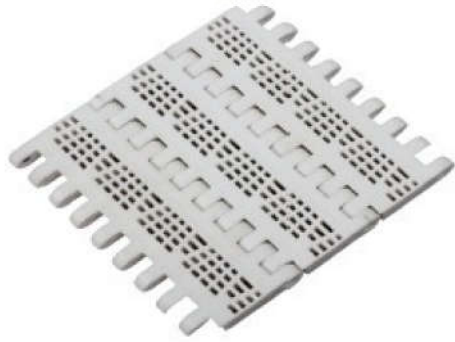

OPB+ mesh chain base flights

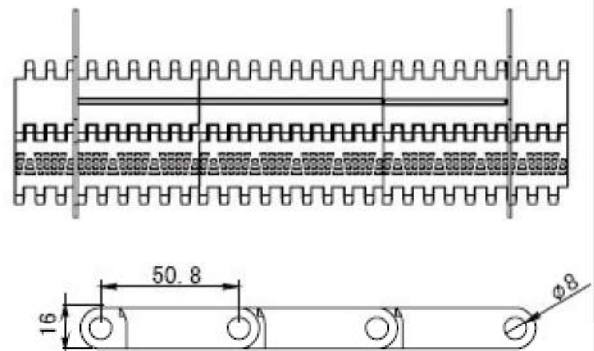
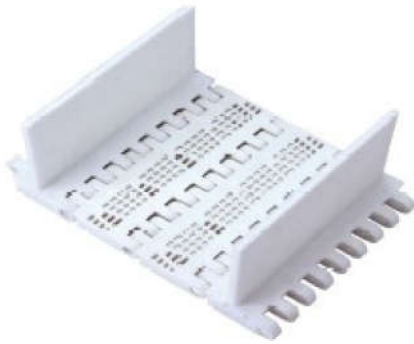

OPB+baffle+ sideguards

